

PRECISO CL- SERIES

CL50C/70C

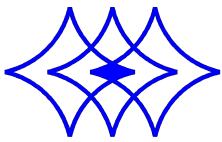



TOP TECH

Instruction

Powerful light
Chamber illumination

Viewing
Machine viewing window

Hand wheel
Manual type

Control panel
Easy and clear



Vise
Fastener vise

Cut off blade
In x direction ↙ ↗

Spindle
1HP/2HP/3H

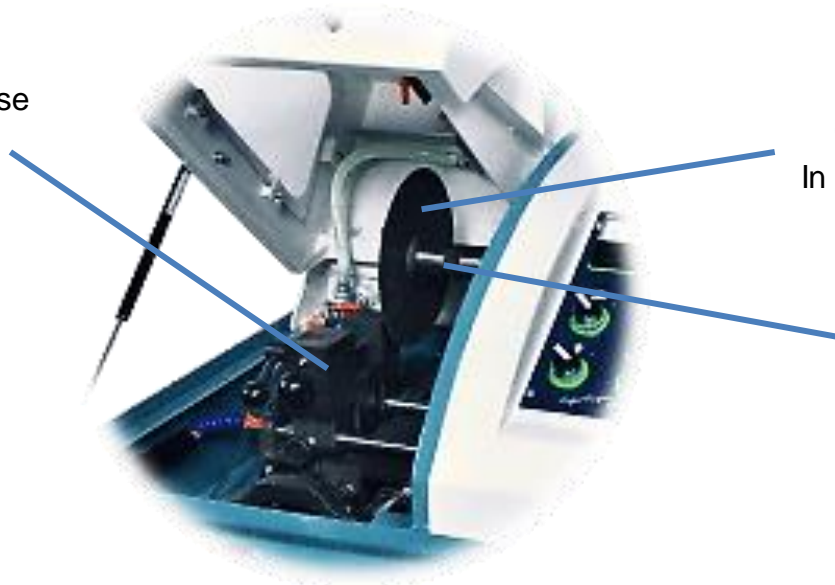

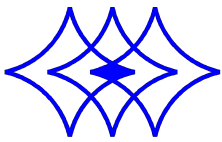

TOP TECH

Feature



- Table top
- Streamlined shape with lively color



- Control button- simply, functional, longer life
- Symbol with picture gives clear and easy understanding
- Safety first with E. STOP



- Moveable tank can storage inside or outside
- Tank with anti-drop, sediment function
- Water tank with quick connector
- Coolant level gauge

Quick-release vise, easy to operate
moves horizontal way in 25mm



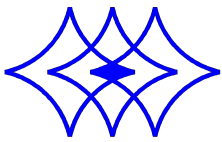

TOP TECH

Worthy Options - Working Table



Working Table

Multifunctional working table, it supplies you a place to put your machine and store your accessories. It can be moved easily.

| Model No. | TF01 | TF02 |
|-----------|---|---|
| Size | 1000*800*700 mm | 1200*1000*700 mm |
| Sample |  |  |

Specification

| Specification | CL50C | CL70C |
|---|---|-------------------------------------|
| Sample Dim. Max.(mm) | Max \varnothing 50 mm 20t×60L | Max \varnothing 70 mm 20t×100L |
| Cut off blade | \varnothing 255 mm | \varnothing 305 mm |
| Feed method | Hand wheel | |
| Rotational speed | 3000RPM | 2500RPM |
| Cutting depth | 200 mm | 260 mm |
| Cutting method | Horizontal | |
| Vise | Fastener vises (clamping) | Fastener vises (clamping) |
| Motor power | 2HP (1500W) | 3HP (2300W) |
| Machine dimension | 850mm(W)x900mm(D)x500mm(H) | 950mm(W)x1100mm(D)x500mm(H) |
| Machine type | Table-top | |
| Power supply | 3 \varnothing -AC220V (AC380V) | |
| Machine weight (Kg) | 160 | 210 |
| Standard accessories | Tool one set, cutting off blade two pcs | |
| Water tank | 50L | |
| Adjustable spindle rotation speed (option) | 3000RPM \pm 50%(CK-004) | 2500RPM \pm 50%(CK-004) |

※ All right reserved by Top Tech.

Parameter

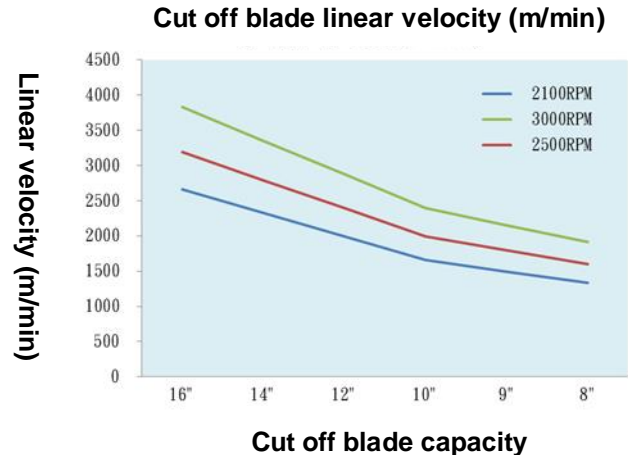
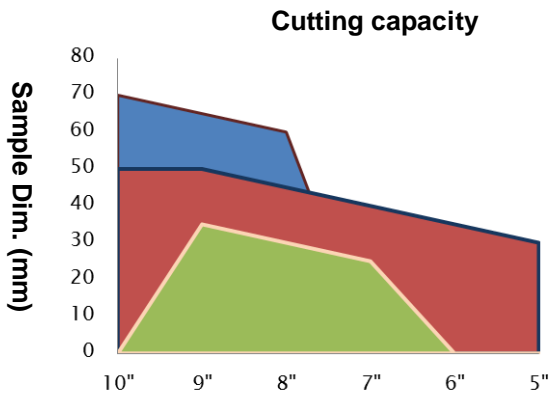

1. Parameter for reference only.
2. Actual cutting range related to sample material, feed rate, cutting rate, vise, etc.

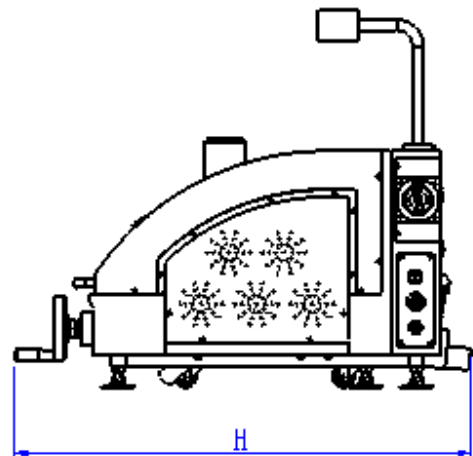
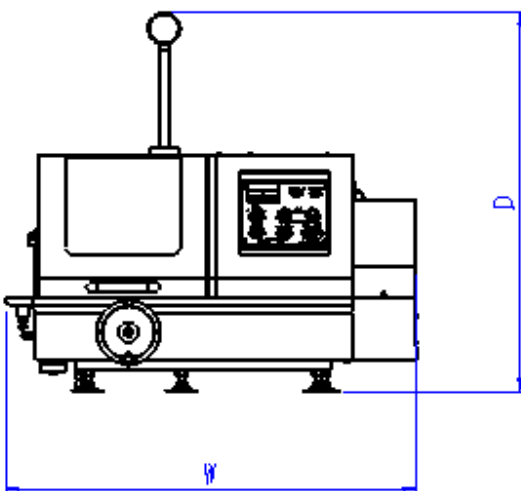

Consumables

CUT OFF BLADES

| No | DESCRIPTION | SIZE | Q'TY/PACK |
|----|---|-------------|-----------|
| 1 | TS-soft steels | Ø9"(230mm) | 10 |
| 2 | TM-medium & hard steels | Ø9"(230mm) | 10 |
| 3 | TH-hard & very hard steels | Ø9"(230mm) | 10 |
| 4 | TS-soft steels | Ø10"(254mm) | 10 |
| 5 | TM-medium & hard steels | Ø10"(254mm) | 10 |
| 6 | TH-hard & very hard steels | Ø10"(254mm) | 10 |
| 7 | Non Ferrous Material, Titanium, Cost Iron | Ø10"(254mm) | 10 |
| 8 | TS-soft steels | Ø12"(305mm) | 10 |
| 9 | TM-medium & hard steels | Ø12"(305mm) | 10 |
| 10 | TH-hard & very hard steels | Ø12"(305mm) | 10 |
| 11 | TS-soft steels | Ø14"(355mm) | 10 |
| 12 | TM-medium & hard steels | Ø14"(355mm) | 10 |
| 13 | TH-hard & very hard steels | Ø14"(355mm) | 10 |
| 14 | TS-soft steels | Ø16"(406mm) | 10 |
| 15 | TM-medium & hard steels | Ø16"(406mm) | 10 |
| 16 | TH-hard & very hard steels | Ø16"(406mm) | 10 |

COOLANT

| No. | DESCRIPTION | SIZE | Q'TY/PACK |
|-----|-----------------------|------|-----------|
| 1 | OIL BASED-Transparent | 1L | 20L |



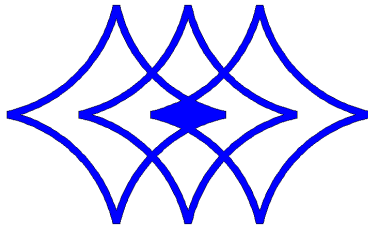

TOP TECH

*Perfect Surface.
Always*

Cutting / Mounting / Grinding & Polishing / Spin Coater

TOP TECH MACHINES CO.,LTD

No.6-3,Siyuan Rd.,Dali,Taichung,412 Taiwan

Tel:886-4-24061658

Fax:886-4-24073200

<http://toptech.snjapp.com>

E-mail: top@toptech.tw

Agent

**We reserve the right of
changing design.
2014 NO.01**



<http://www.toptech.tw>